

# MODEL WSP-CP

(2,3inch Panel Printer with Auto cutter)

Rev. 5.1

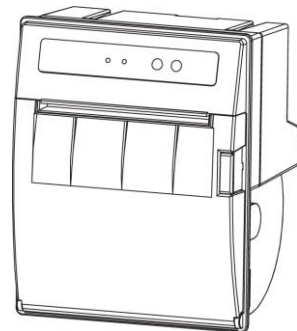
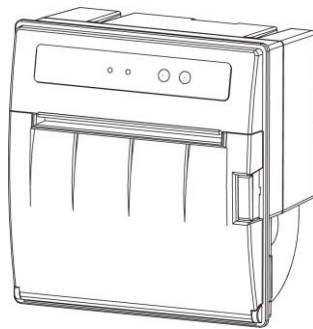
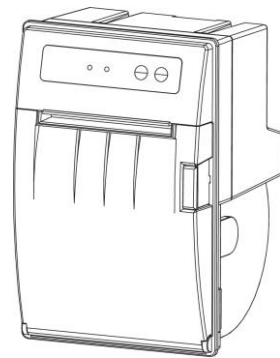
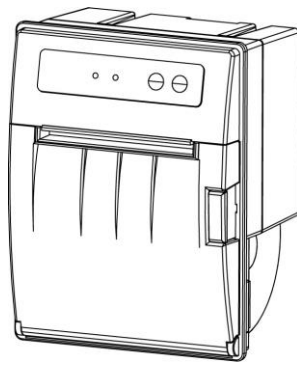

All specifications are subjected to change without notice

## ■ Copyright

WSP-CP(261, 281, 361, 381)

2,3inch panel printer(with Auto cutter) operator's manual.

Copyright ©2017 by Woosim Systems Inc.

All rights reserved.

The information contained in this manual is the property of Woosim Systems Inc.

And may not be reproduced in whole or in part without the prior written permission of Woosim Systems Inc.

## ■ Trademark



a registered trademark of Woosim Systems Inc.

All other trademark are the properties of their respective companies.

## ■ Caution

Some semiconductor devices are easily damaged by static electricity. You should turn the printer "OFF", before you connect or removed the cable on the rear side, in order to guard the printer against the static electricity.

If the printer is damaged by the static electricity, you should turn the printer "OFF"

## ■ Notice

The contents of this manual are subject to change without notice.

## ■ Introduction

The **WSP-CP** is an extremely simple and functional panel printer.

It is the ideal solution for applications which require the immediate printing of data on a paper, whether they be of an industrial, professional or laboratory nature.

Medical analyzer, Industrial instrument, Recorder, Geological analyzer, Underground analyzer, Chemical analyzer, Metallic analyzer, etc.

The general features of WSP-CP printer are as follows:

- ▶ Very silent printing thru direct thermal printing method.
- ▶ High speed(200mm/sec-3inch, MAX)
- ▶ UART(RS-232C or TTL), USB interface.
- ▶ Auto cutting
- ▶ Support text and graphic printing.
- ▶ Intuitive LED's indicate Power(on/off), Error
- ▶ Easier paper loading by CLAMSHELL design.
- ▶ Easier maintenance with self-diagnostic.
- ▶ One touch paper cover
- ▶ In field programming – Update Firmware, Download Fonts and Logos
- ▶ Microsoft Windows/Windows CE, Linux, Android compatible
- ▶ Flow control : Software (XON/XOFF)
  - ※ Hardware flow control not supported in printer.
- ▶ Agency Approvals



## ► Using the Printer

- Be careful not to drop or bump the printer on a hard surface.
- Do not install the printer in direct sunlight or such areas.  
Suitable environment for the use of the printer is as follows:
  - ◆ Operating temperature :-10°C to 50°C
  - ◆ Relative humidity : 30% to 80%
- Do not install the printer near devices that generate strong electromagnetic fields such as a copy machine.
- Do not open the platen cover during printing .
- Do not remove or reinstall the communication cable during printing or transmission.
- Do not touch the connectors of the communication during printing.
- Switch the POWER OFF when not in use.
- Do not use other solvent.

## ► Thermal Paper Handling

- Store the thermal paper in a cool, dry and dark place.
- Do not rub the paper with hard object.
- Do not leave the paper with hard object.
- Do not allow plastic film, erasers, or adhesive tape to touch the paper for long periods.
- Do not stack the thermal paper with diazo copies immediately after copying or wet-type copies.
- Do not use chemical glue.
- Always use the clean thermal paper.

# CONTENTS

<b>1. Outline .....</b>	<b>6</b>
1.1. Model classifications .....	6
1.2. Product Part Number System.....	6
1.3. Specifications.....	7
<b>2. Setting up the printer.....</b>	<b>9</b>
2.1. Printer & Accessories .....	9
2.2. Printer Features.....	10
2.3. Dimension .....	11
2.4. Panel Installation I .....	13
2.5. Panel Installation II.....	14
2.6. Replacing paper roll.....	16
2.7. Specified power supply.....	16
<b>3. Interface.....</b>	<b>17</b>
3.1. UART (RS-232C or TTL) or USB.....	17
<b>4. Using the printer.....</b>	<b>18</b>
4.1. Control panel .....	18
4.2. The self test.....	18
<b>5. Consumable Parts.....</b>	<b>19</b>
5.1. Recommended paper.....	19
5.2 Printing position .....	19
<b>6. Revision History.....</b>	<b>20</b>

# 1. Outline

## 1.1. Model classifications

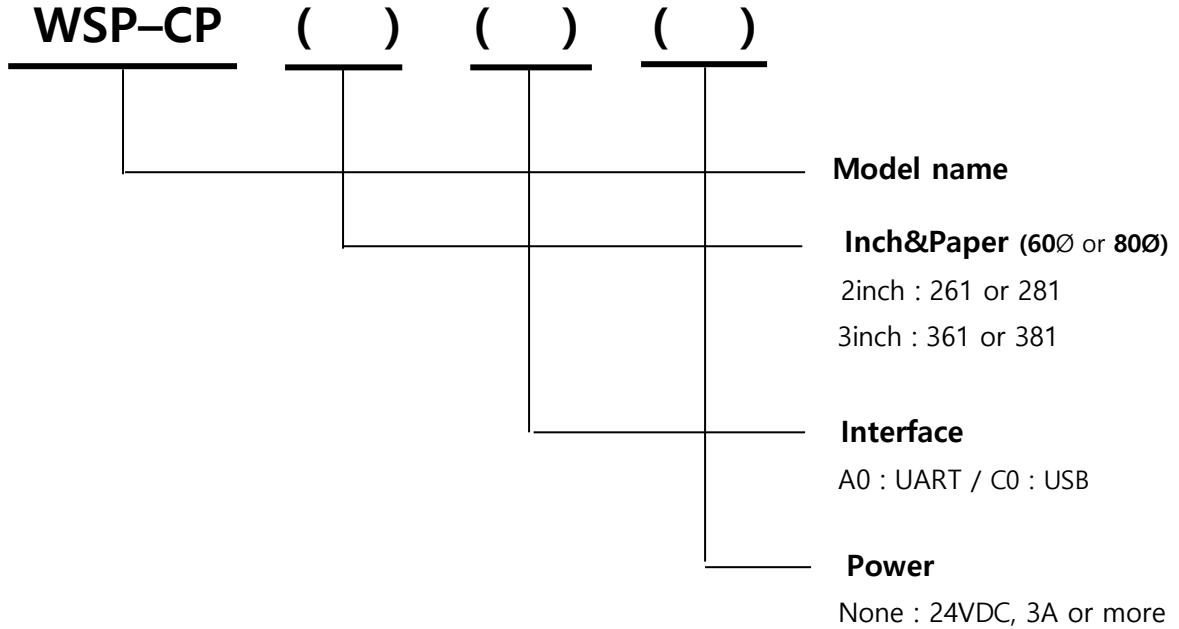

## 1.2. Product Part Number System

**Model name / Interface Spec.**

<p>S40</p> <p>SC30</p> <p>W25</p> <p>.</p> <p>.</p>	<table border="1" style="width: 100%; border-collapse: collapse;"> <thead> <tr> <th colspan="2">Wired</th> <th colspan="2">Wireless</th> </tr> </thead> <tbody> <tr> <td>A</td> <td>RS-232C</td> <td>1</td> <td>Bluetooth</td> </tr> <tr> <td>B</td> <td>TTL</td> <td>2</td> <td>IrDA</td> </tr> <tr> <td>C</td> <td>USB</td> <td>0</td> <td>None</td> </tr> <tr> <td>D</td> <td>RS-485</td> <td></td> <td></td> </tr> <tr> <td>E</td> <td>Parallel</td> <td></td> <td></td> </tr> <tr> <td>Z</td> <td>None</td> <td></td> <td></td> </tr> </tbody> </table>	Wired		Wireless		A	RS-232C	1	Bluetooth	B	TTL	2	IrDA	C	USB	0	None	D	RS-485			E	Parallel			Z	None		
Wired		Wireless																											
A	RS-232C	1	Bluetooth																										
B	TTL	2	IrDA																										
C	USB	0	None																										
D	RS-485																												
E	Parallel																												
Z	None																												

Example) 1. Porti-S40    UART/Bluetooth    Part No. ⇒ S40/A1  
 2. Porti-SC30    Bluetooth Only    Part No. ⇒ SC30/Z1

Note) The above table is the interface format which is supported.  
 But some of the interfaces are not supported according to the product  
 and please contact us, if you have any questions regarding the interface.

### 1.3. Specifications

Item	Specification	
	2inch (CP261, CP281)	3inch(CP361, CP381)
<b>Print method</b>	Thermal dot line printing	
<b>Characters per line</b>	- Font A, B, C : 32 / 42 / 48cpl - KOR, CHN, JPN : 16cpl (24cpl)	- Font A, B, C : 48 / 64 / 72cpl - KOR, CHN, JPN : 24cpl (36cpl)
<b>Character size</b>	- Font Size A: 12X24 / Font Size B : 9X24 / Font Size C : 8X16 - KOR : 24X24(16X24) / CHN, JPN : 24X24	
<b>Optional Characters</b>	Alphanumeric:95, Extended Graphics:128X50 pages, International:10, Simplified/Traditional Chinese, Japanese, Korean	
<b>Resolution</b>	203dpi, 8dots/mm	
<b>Print width</b>	7V : 48mm, 384dots 24V : 54mm, 432dots	72mm, 576dots
<b>Paper roll</b>	58mm (60ø, 80ø)	80mm (60ø, 80ø)
<b>Print speed</b>	7V : 80mm/sec (MAX) 24V : 150mm/sec (MAX)	7V : 80mm/sec (MAX) 24V : 200mm/sec (MAX)
<b>Dimension</b>	261 : 91.1 x 115.2 x 66.6 mm 281 : 91.1 x 136.2 x 90.1 mm	361 : 113.1 x 115.2 x 66.6 mm 381 : 113.1 x 136.2 x 90.1 mm
<b>Weight</b> (w/o roll paper)	261 : 290g 281 : 331g	361 : 334.6g 381 : 383.5g
<b>Interface</b>	UART(RS-232C or TTL), USB	
<b>Barcodes</b>	1-dimension : UPC-A, UPC-E, EAN-8, EAN-13, CODE-39, CODE-93, CODE-128, ITF, CODABAR 2-dimension : PDF417, Micro PDF417, Truncated PDF417, QR-CODE, DATA Matrix, Maxicode Etc :GS1 databar	
<b>Driver</b>	Microsoft Windows, Linux	
<b>H/W spec</b>	MCU : RX-32bit, RAM : 128M bit, FLASH : 64M bit	
<b>Receive buffer size</b>	1M bytes	
<b>Paper cutting method</b>	Slide cutting	
<b>Type of paper cutting</b>	Full cut and Partial cut (1.5±0.5mm tab left at the center)	
<b>Input Power</b>	24VDC, 3A or more	

(Continue...)

Item	Specifications	
Environment conditions	Temperature	-10°C ~ 50°C (operating) -20°C ~ 60°C (storage)
	Humidity	30% - 80% (operating)
Life span (at 25°C and rated energy)	Activation pulse resistance	100 million pulses or more
	Abrasion resistance	100km or more (excluding damage caused by dust and foreign materials)
	Paper cutting resistance	700,000 cuts or more

&lt; Table 1 &gt;



## 2. Setting up the printer

### 2.1. Printer & Accessories

Your printer box should include these items. If any items are damaged or missing, please contact your dealer for assistance.

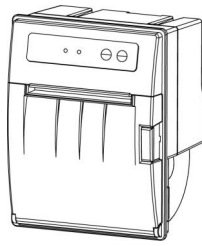

WSP-CP261

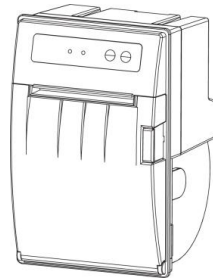

WSP-CP281



WSP-CP361

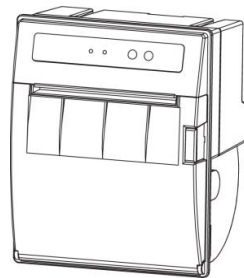

WSP-CP381

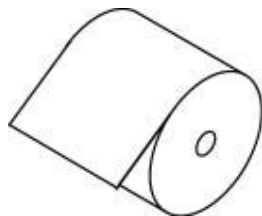

Thermal roll paper

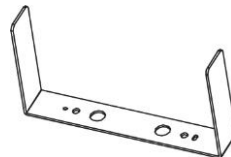

Bracket



Screw M2.6x5PH  
(2EA)

## 2.2. Printer Features

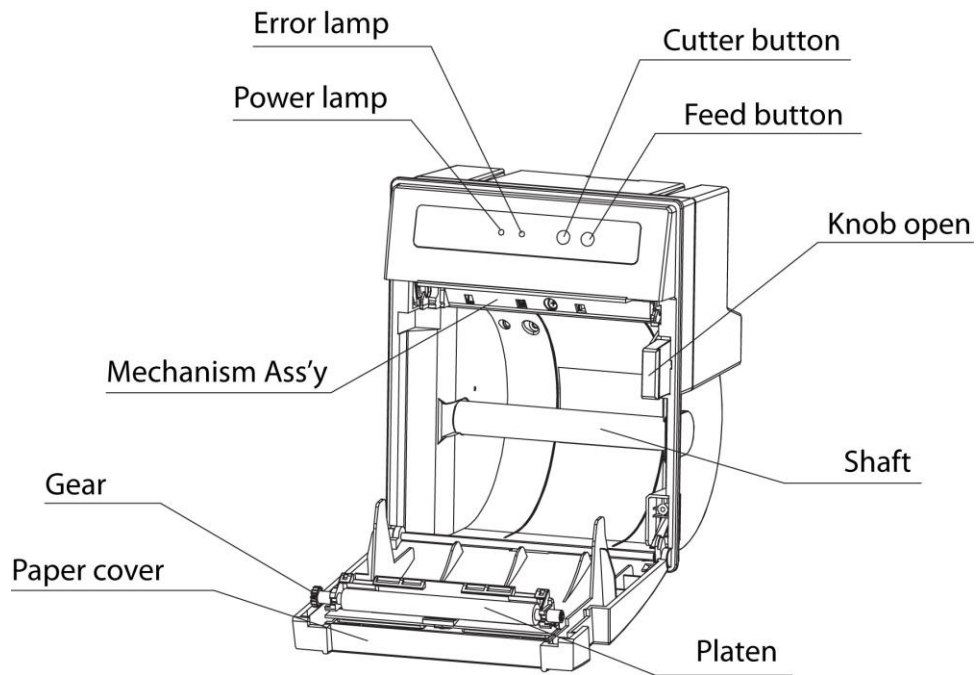

### 2.3. Dimension

#### CP261

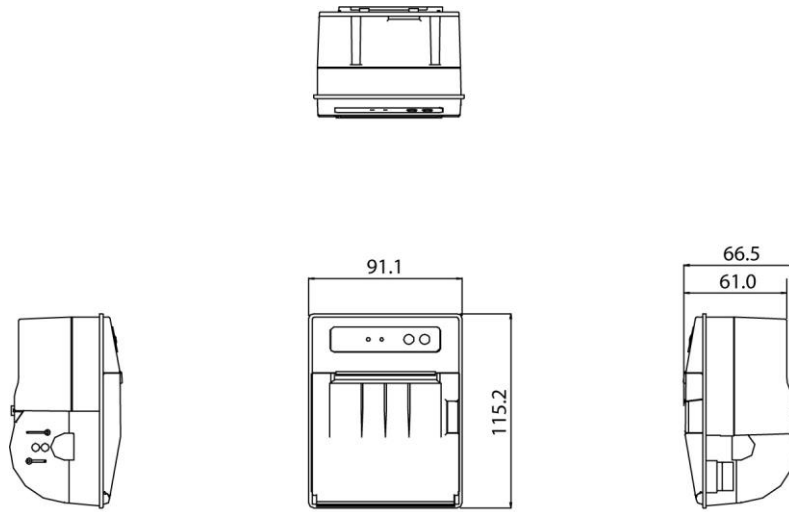

#### CP281

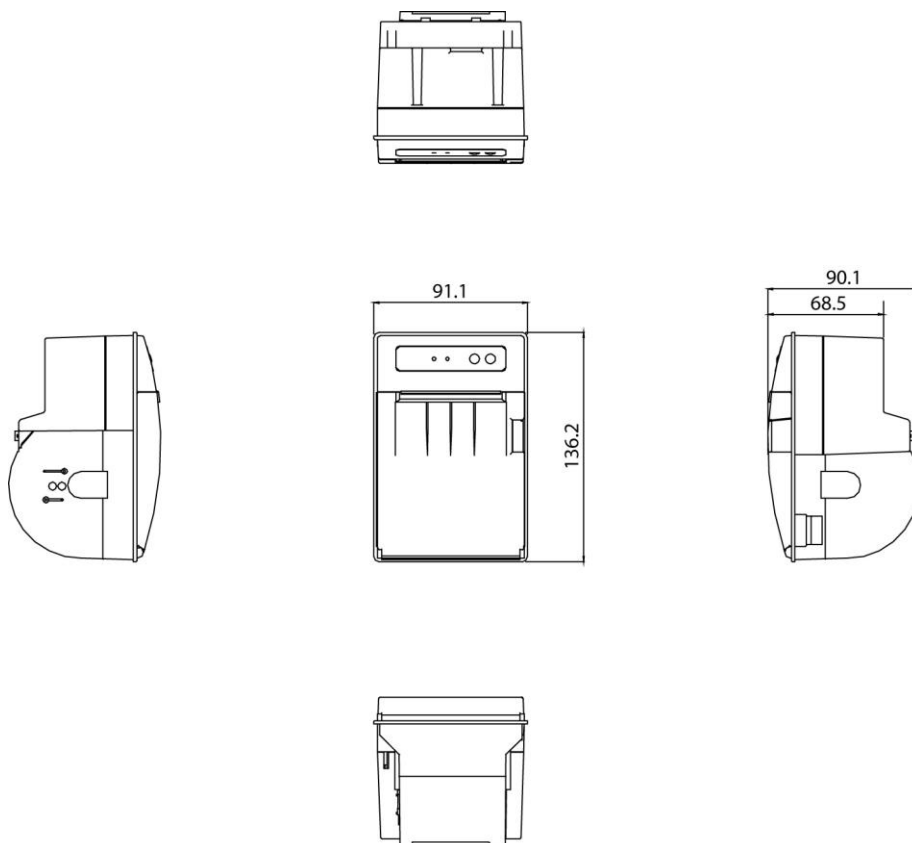

CP361

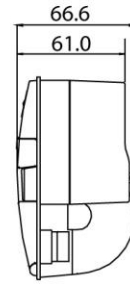
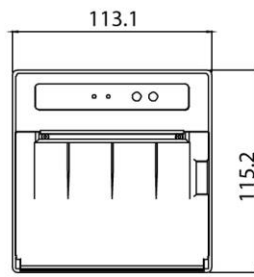
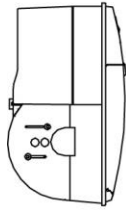
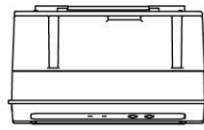

CP381

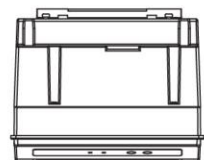
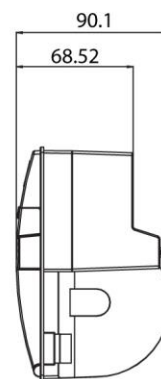
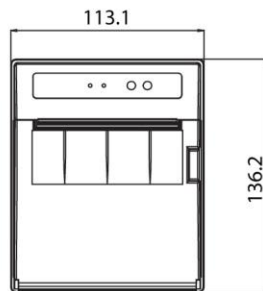
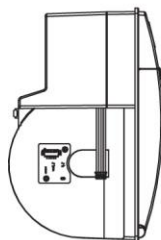
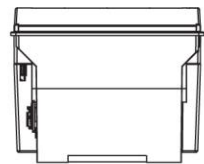

## 2.4. Panel Installation I

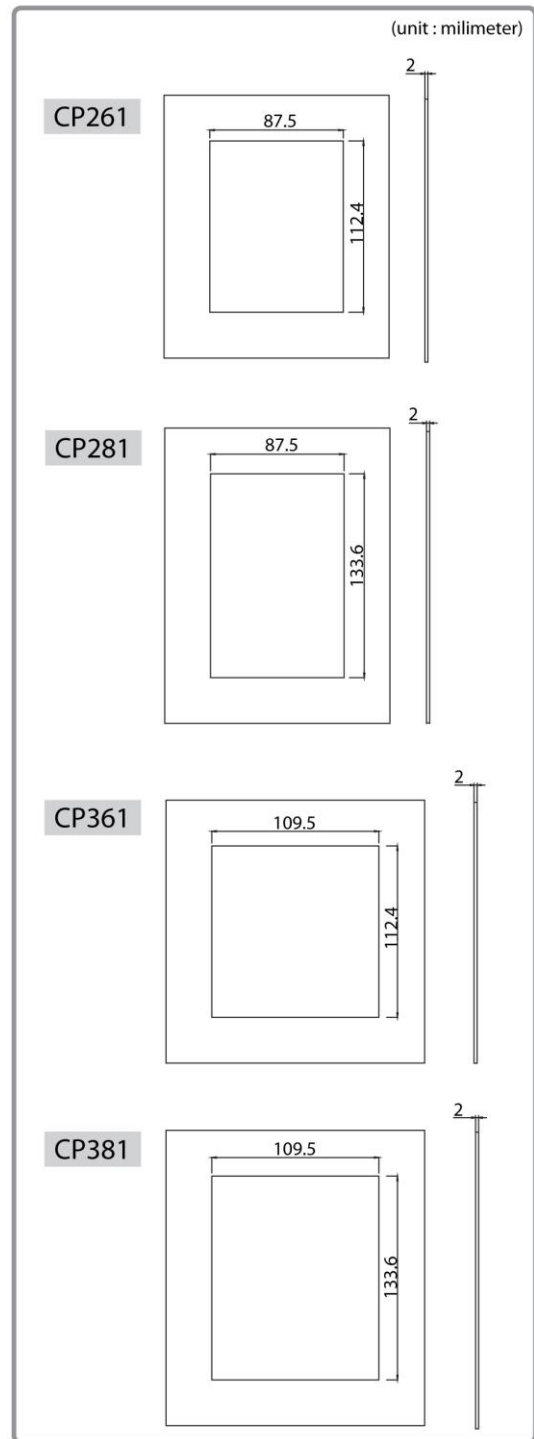
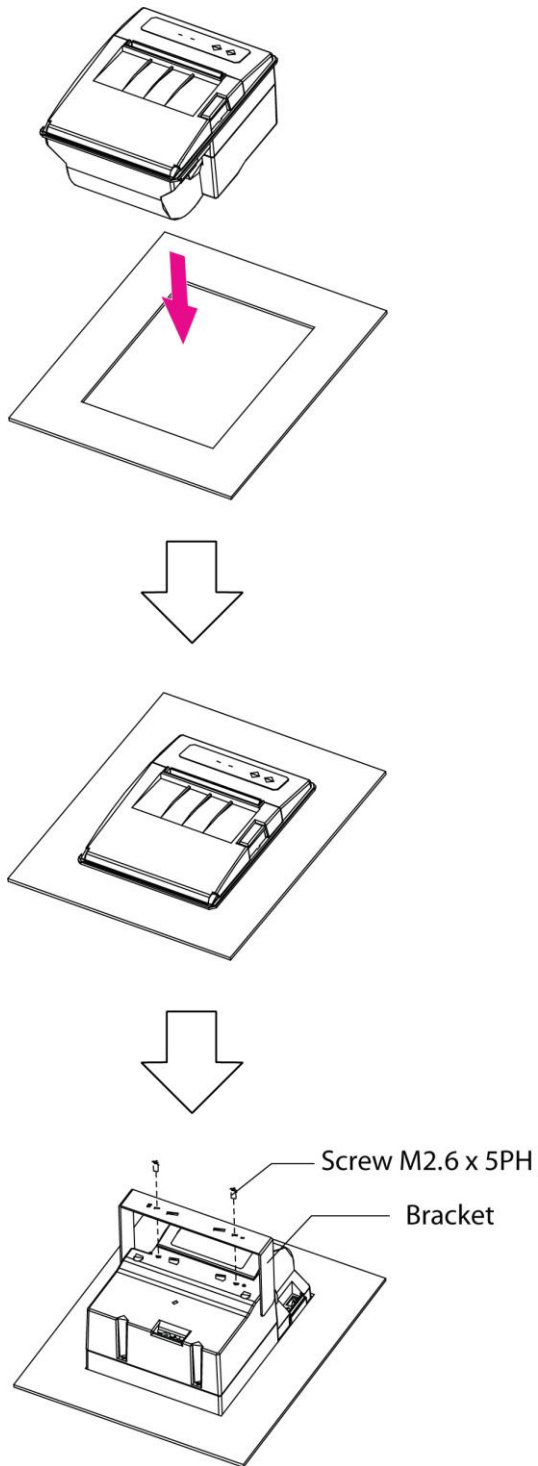

## 2.5. Panel Installation II

Uses BRACKET and fixes, like the picture of difficult case lower part and will be able to fix with SCREW.

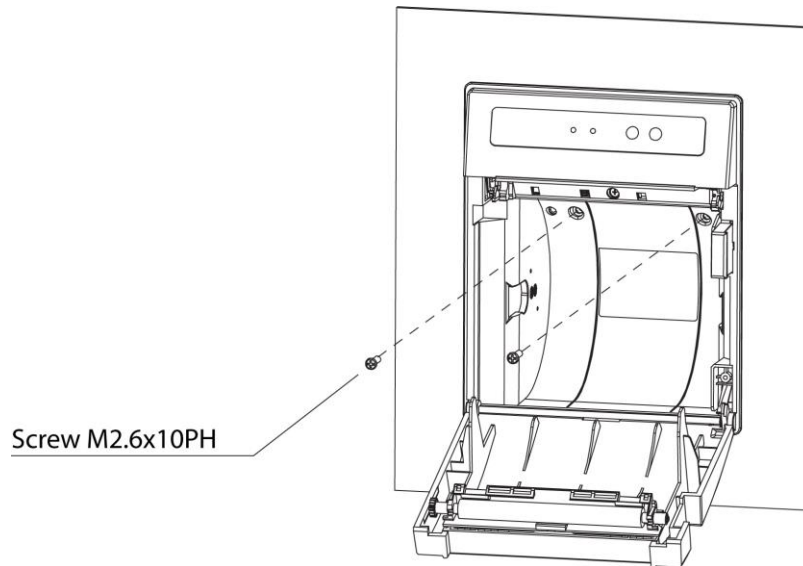

CP261

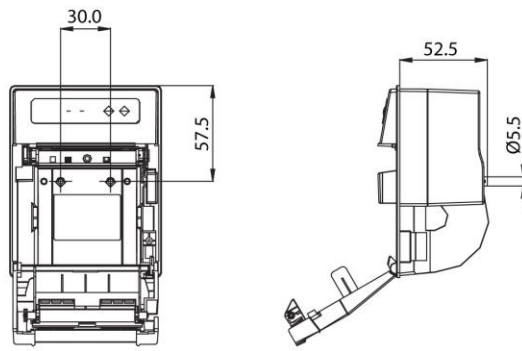

CP281

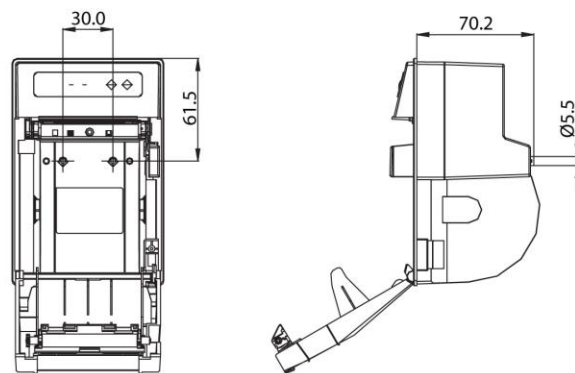

CP361

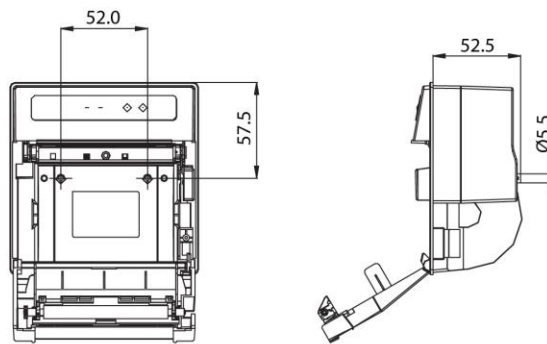

CP381

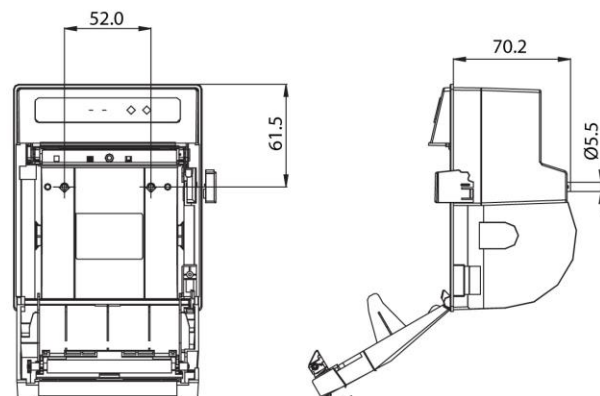

## 2.6. Replacing paper roll

**Note :** Be sure to use paper rolls that meet the specifications.

Do not use paper rolls that have the paper glued to the core because the printer cannot detect the paper end correctly.

1. Make sure that the printer is not receiving data; otherwise, data may be lost.
2. Open the paper cover as the "One-Touch" way by pressing the button in the arrow direction like the picture

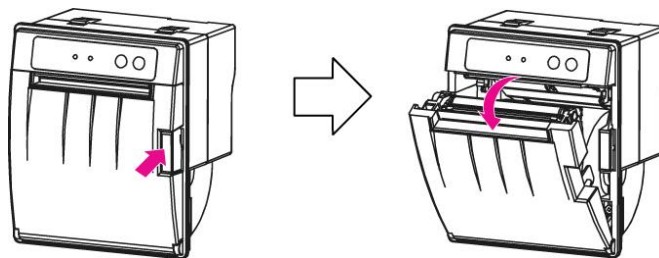

3. Insert a new paper roll as shown.

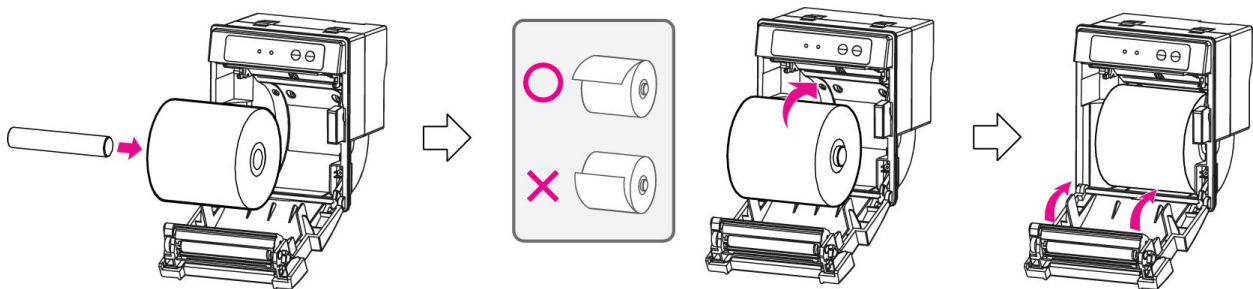

4. Tear the excess paper off using the edge of paper door as a tear bar.

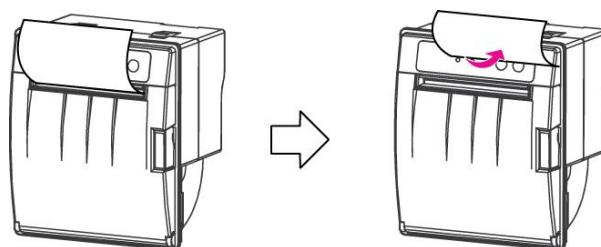

## 2.7. Specified power supply

The following specifications are requested for power supply.

Input : DC 24V / Max 3A or more

Avoid using power supply which its power capacity of power current is extremely high.



### 3. Interface

#### 3.1. UART (RS-232C or TTL) or USB

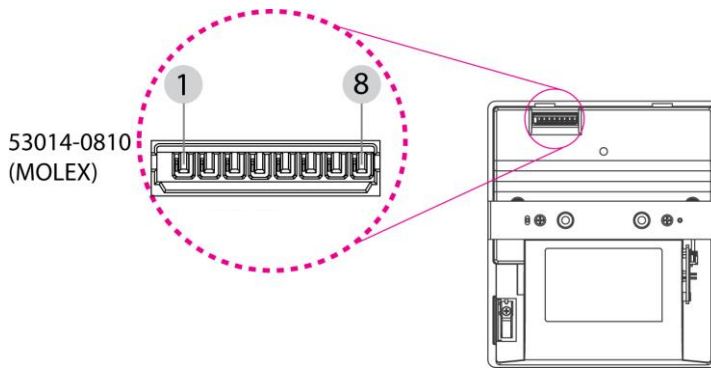

The WSP-CP printer has UART(RS-232C or TTL) or USB interface and power connector is connected by 8 pin female connector.

In the following table, the signals present on the connector are listed:

Pin no.	Signal name		Function	
	UART	USB	UART	USB
8	INPUT		24VDC / 3A over	
7	INPUT		24VDC / 3A over	
6	TXD	USB_VCC	Transmit Data	5VDC
5	RXD	DM	Receive Data	Data "-"
4	NC	DP	-	Data "+"
3	GND		Ground	
2	GND		Ground	
1	GND		Ground	

<J4 : MOLEX (53014-0810)>

Mates with : MOLEX 51004-0800 or equivalent.



**WARNING**

A wrong connection of power supply connector could be damage the printer.

## 4. Using the printer

### 4.1. Control panel

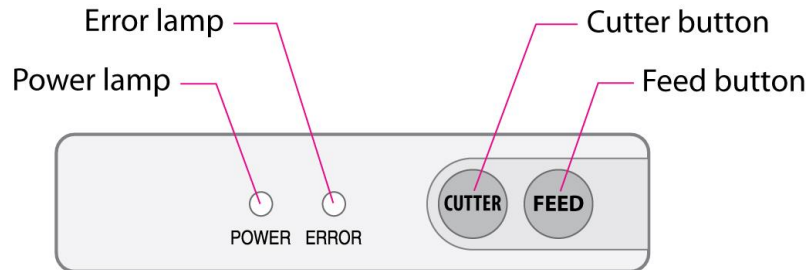

#### ► BUTTON

- **FEED** : When the printer is on, paper can be feed manually by pressing and holding the FEED button for more than one second.
- **CUTTER** : Paper once cutting.

#### ► PANEL LAMP

- **Power(Green)** : Printer is ON and ready to receive data.  
At the time of the reel which will know the shift time of the paper POWER LAMP blinks.
- **Error (Red)** : Indicates a fault condition or a printer error.  
(details : no paper, paper cover opened. etc.)

### 4.2. The self test

Self-Test prints out the current setting value of printer. The way of self-test is as follows.

1. Insert proper paper into the printer.
2. Power on while pressing feed button to start self-test.
3. Printer will print out the current status. (F/W version and set contents)
4. And then pattern of characters will be printed out.
5. Self-test will be finished automatically and turned to the standby status.

※ In case printer does not work properly, please contact Woosim customer service center.

## 5. Consumable Parts

### 5.1. Recommended paper

Type	: Thermal Paper
Paper width	: 58mm(2-inch), 80mm(3-inch)
Paper thickness	: $60 \pm 5\mu\text{m}$
Outer diameter	: $\varnothing 60$ , $\varnothing 80\text{mm}$ or less
Recording side	: Outside of roll



### Cautions

1. Do not paste the paper to the core. And the roll paper which has Near end mark printing on its near end is recommended.
2. Chemicals or oil may change the color of paper, or printed Characters may fade.
3. Change of paper color starts from approx 70 °C.  
Pay attention to heat, humidity and sun light.
4. Color of paper may be changed by being scratched by nail or hard metal, etc

### 5.2 Printing position

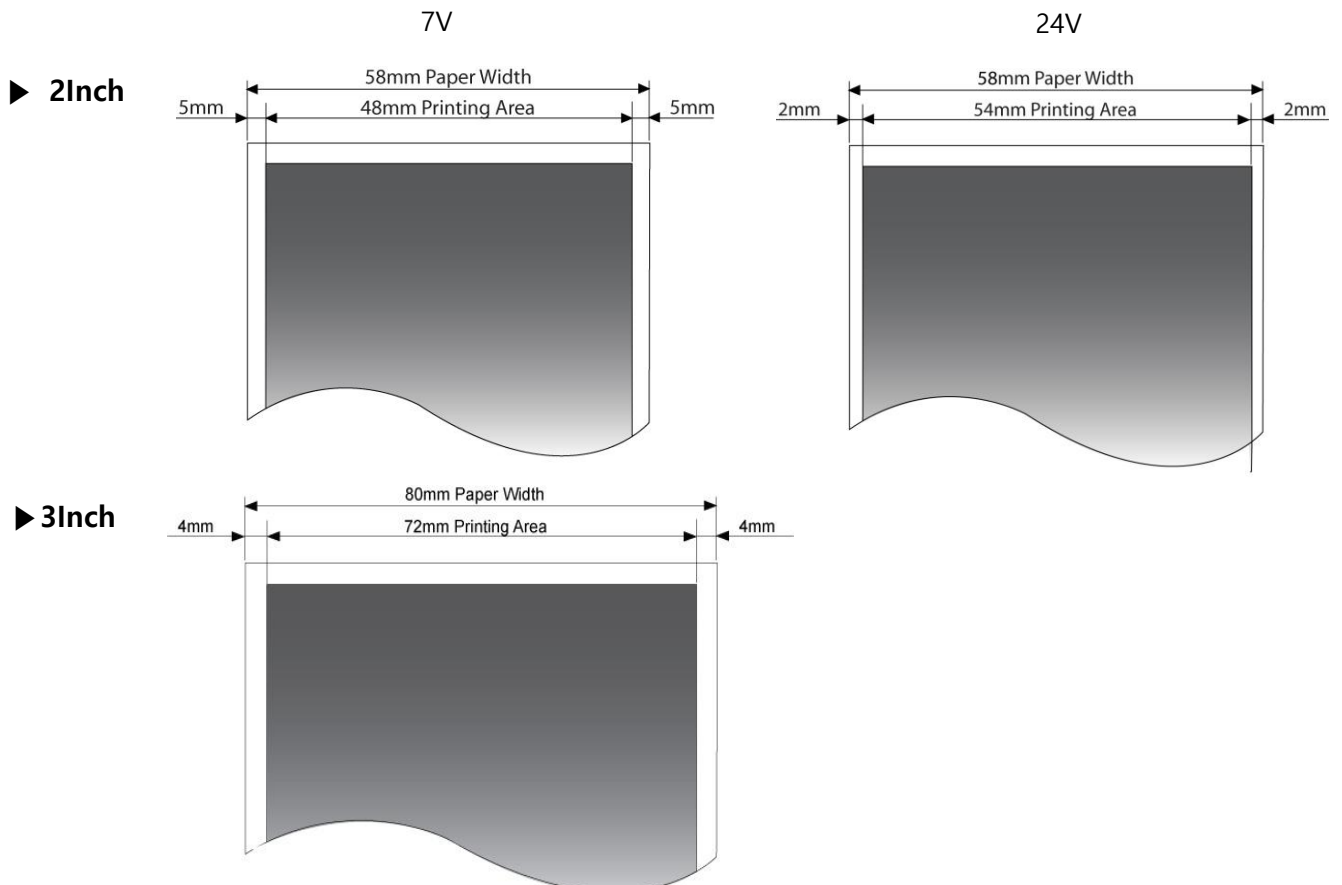

## 6. Revision History

Date	Version	Comments
Dec. 20. 2010	2.0	Revision History Initial Release Product weight revision
Nov. 03. 2011	3.0	P13 2.3. Panel Installation I (CP380 dimension correction)
Jun. 16. 2015	4.0	Mechanism RH type
Sep. 18. 2015	5.0	Correct specification
May. 15. 2017	5.1	Change page layout (B5→A4) * Delete address Agency Approvals add [CE, FCC KC]